



**ALLIED  
MOULDED  
PRODUCTS, Inc.**

**Inspection Window Installation**  
Installation Instructions for Inspection Window  
AMHMI66CX

## Instructions for Installing HMI Cover

**NOTE: Philips Screw Driver or similar tool is required to install cover.**

1. Punch out the template center.
2. Place template on flat smooth surface and mark hole locations and panel opening as shown.
3. Remove template and drill or cut holes and opening accordingly.
4. Mount Inspection Window with supplied mounting hardware. Hardware applicable to mounting surface thickness of .059" - .250". Hardware torque specification 12 - 15 in -lbs.
5. Hardware included:
  - 70-10325, 10-32 X 1/2" Pan Head Machine Screw; Quantity 4
  - 70-EMRWASHER, Stainless Steel Washer; Quantity 4

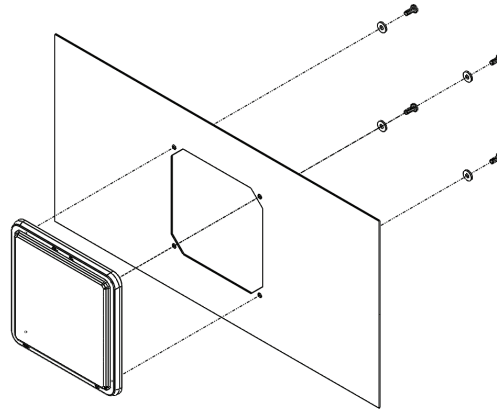

6.50  
[165]

Allied Moulded Products, Inc.  
222 North Union Street • Bryan, OH 43506  
Phone: 1-800-722-2679 • Fax: 1-800-237-7269  
[www.alliedmoulded.com](http://www.alliedmoulded.com)

P/N 17-AMHMI66CX, Rev. 02

— 1 —

© Allied Moulded Products, Inc.

6.50  
[165]