

(4X) SNAP-IN POLYCARBONATE HINGE KNUCKLE

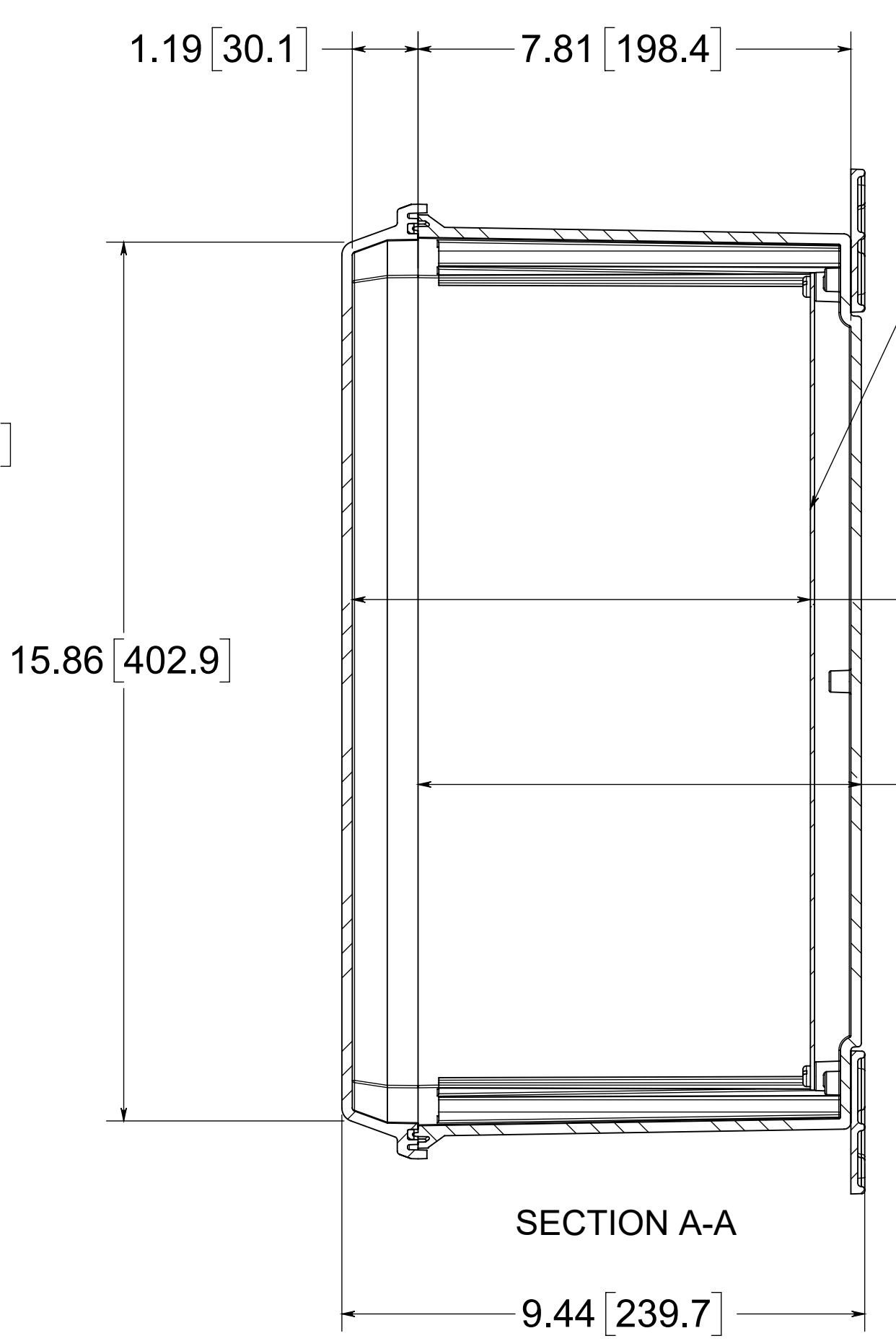

OPTIONAL BACK PANEL  
 0.100 [2.54] TH'K- ALUMINUM  
 0.075 [1.91] TH'K- WHITE STEEL  
 0.188 [4.78] TH'K- PVC

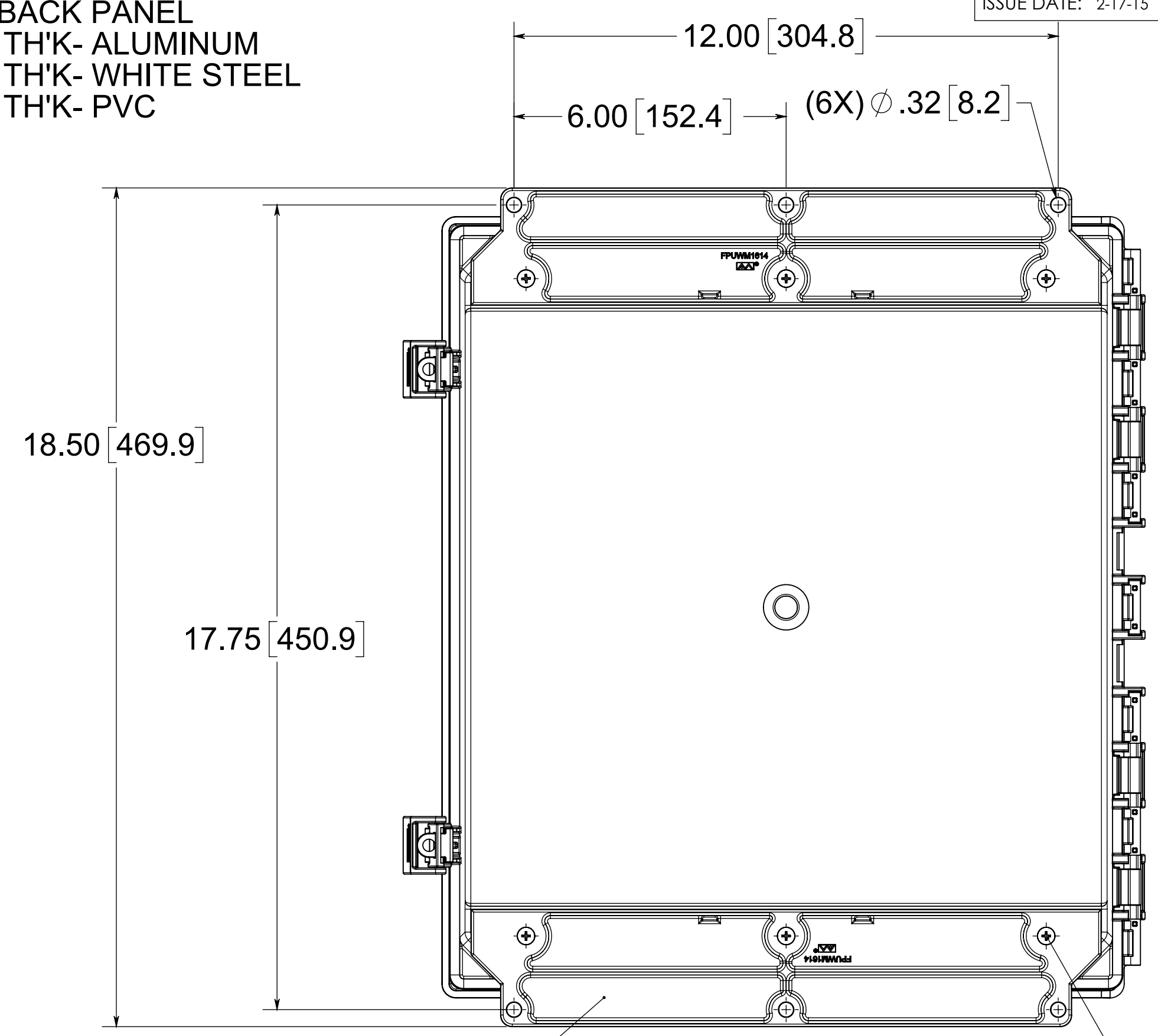

(6X) #10-32 BRASS INSERTS, AND 316 STAINLESS STEEL FLANGE AND FEET SCREWS

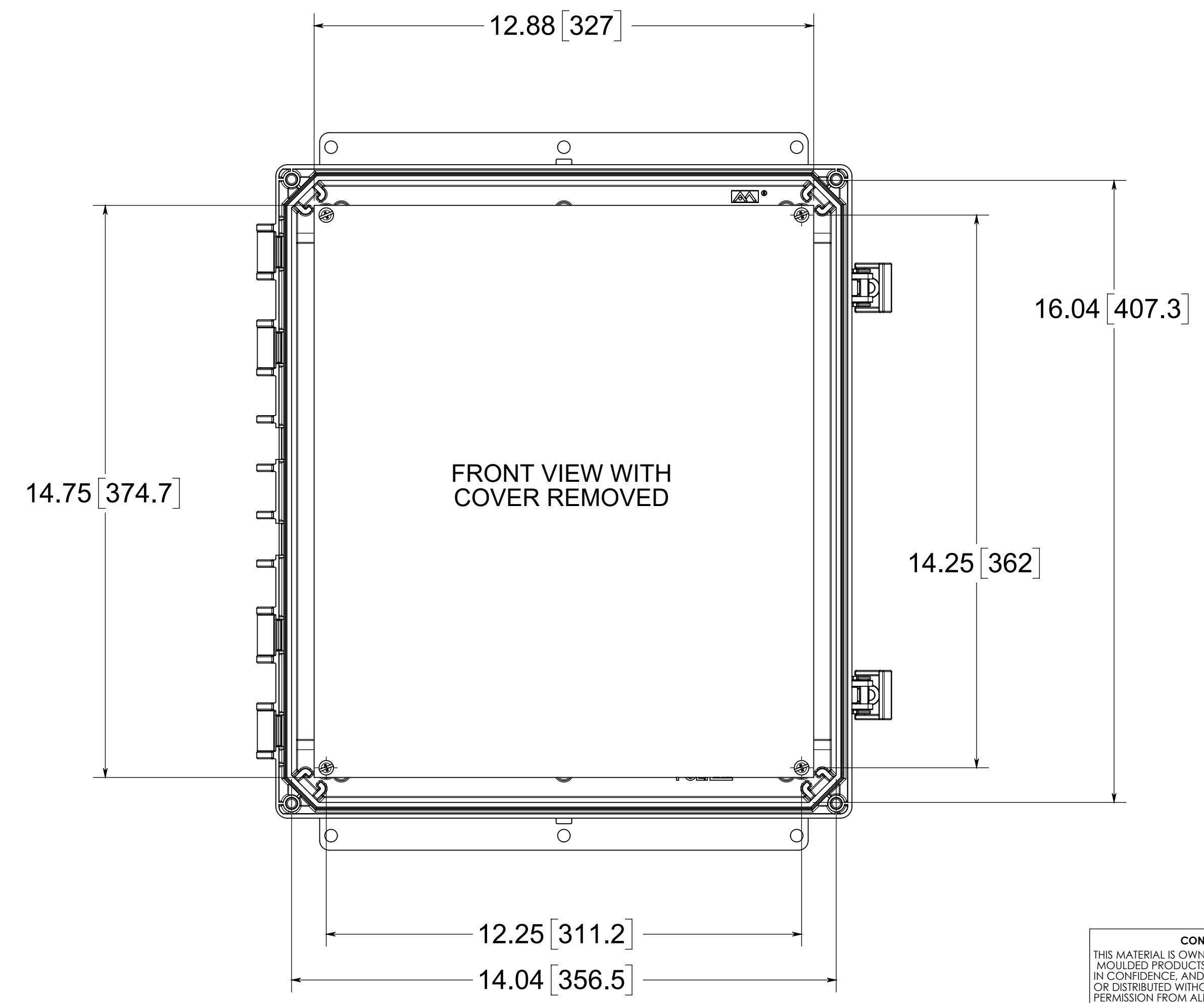
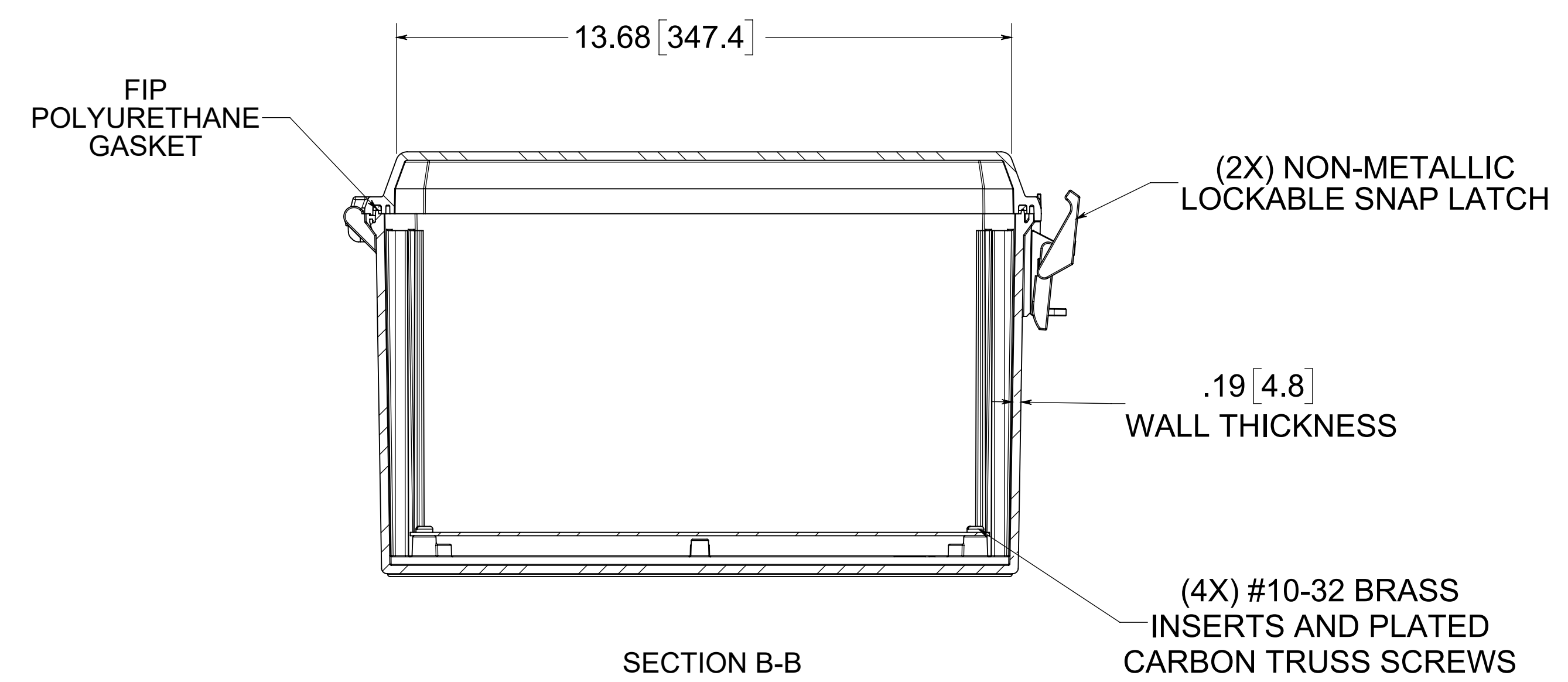

NOTE:  
1. DATA SUBJECT TO CHANGE

MATERIAL:  
 BOX - INJECTED POLYCARBONATE  
 STANDARD COVER - INJECTED POLYCARBONATE  
 CLEAR COVER - INJECTED POLYCARBONATE

AMP POLYLINE  
 AMP1648NLF

CONFIDENTIAL  
 THIS MATERIAL IS OWNED BY THE ALLIED MOULDED PRODUCTS COMPANY, IS DISCLOSED IN CONFIDENCE, AND IS NOT TO BE REPRODUCED OR DISTRIBUTED WITHOUT PRIOR WRITTEN PERMISSION FROM ALLIED MOULDED PRODUCTS.