

OPTIONAL BACK PANEL
 .100[2.54] TH'K - ALUMINUM
 .075[1.91] TH'K - PAINTED STEEL
 .188[4.78] TH'K - PVC

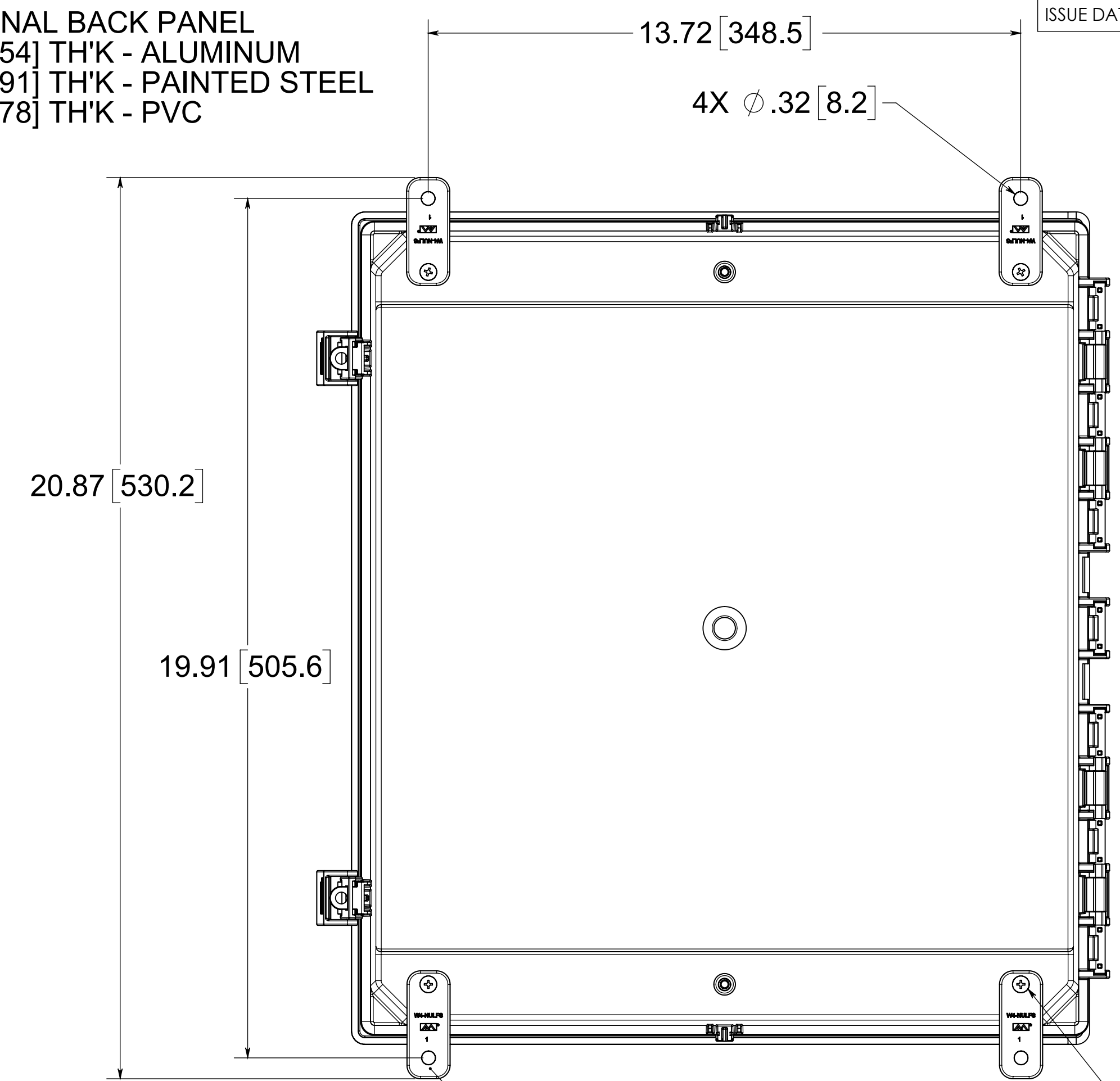

(4X) SNAP-IN
 POLYCARBONATE
 HINGE KNUCKLE

FIP
 POLYURETHANE
 GASKET

(4X)
 POLYCARBONATE
 FEET
 (4X) #10-32 BRASS INSERTS,
 316 STAINLESS STEEL FLANGE
 AND FEET SCREWS

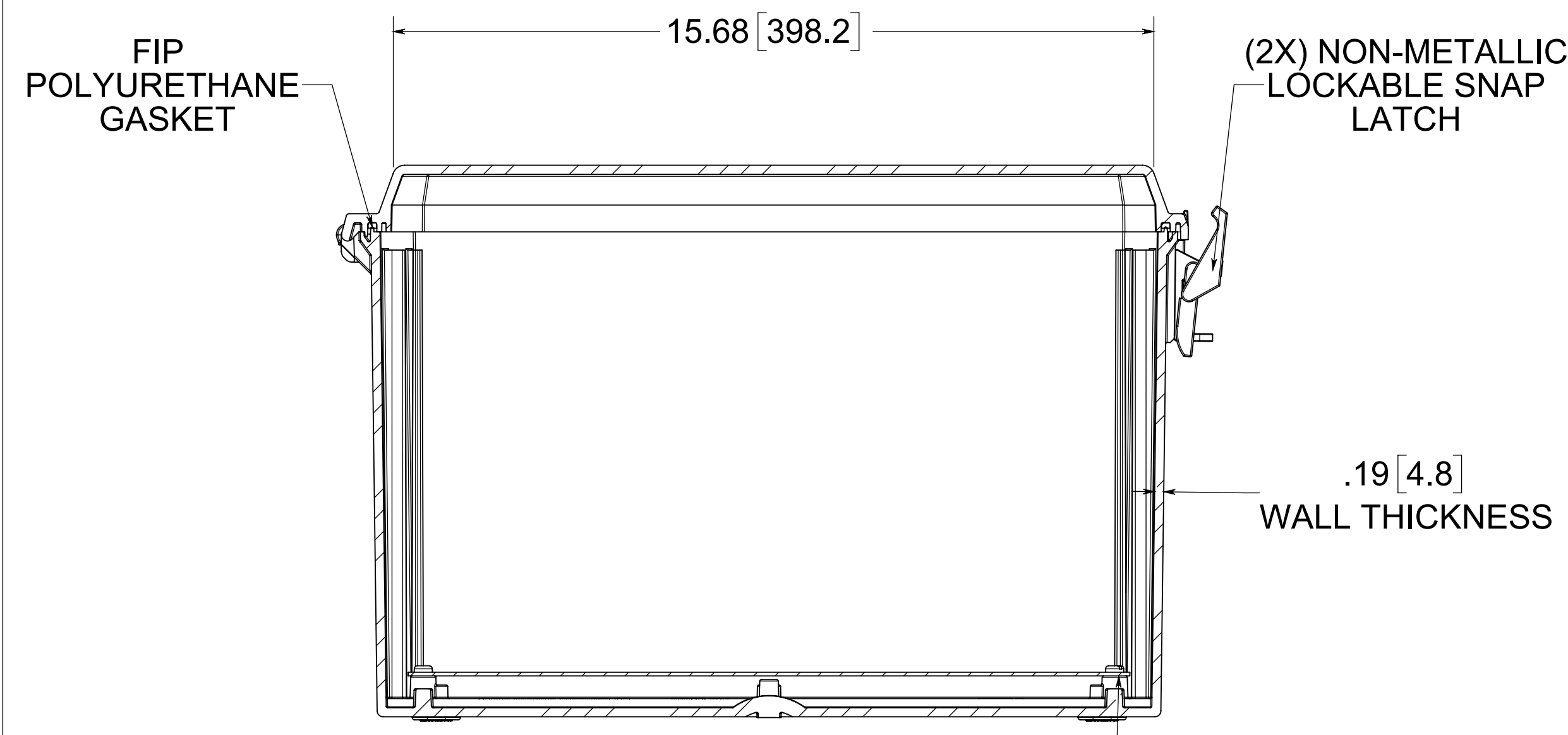

SECTION C-C

(4X) #10-32 BRASS INSERTS
 PLATED CARBON STEEL SCREWS
 TO RETAIN BACK PANEL

MATERIAL:
 BOX: INJECTION POLYCARBONATE
 STANDARD COVER: INJECTION POLYCARBONATE
 CLEAR COVER: INJECTION POLYCARBONATE

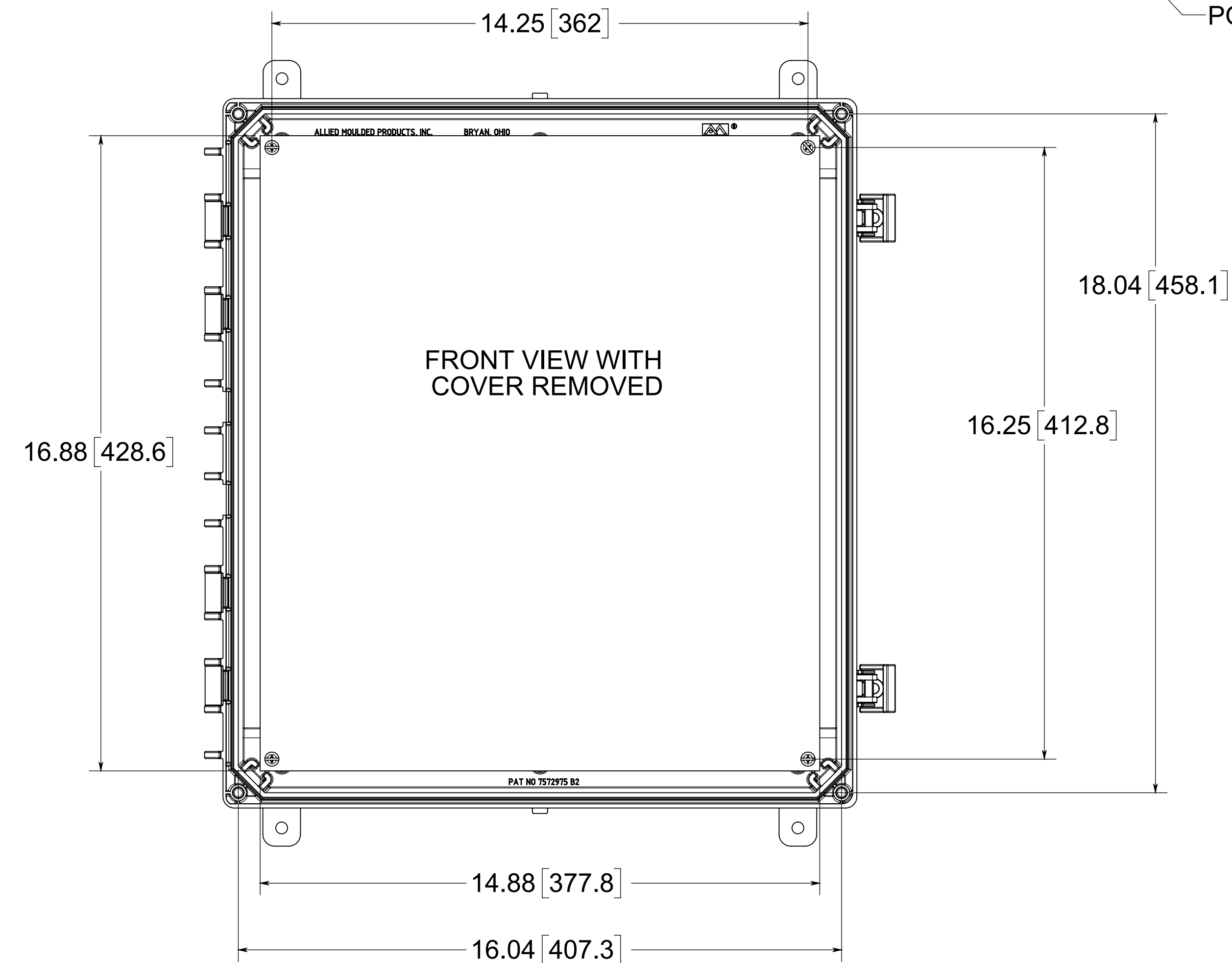

FRONT VIEW WITH
 COVER REMOVED

NOTE:
 1. DATA SUBJECT TO CHANGE

AMP Polyline
 Part No. AMP1860CCNL

CONFIDENTIAL
 THIS MATERIAL IS OWNED BY THE ALLIED MOULDED PRODUCTS COMPANY, IS DISCLOSED IN CONFIDENCE, AND IS NOT TO BE REPRODUCED OR DISTRIBUTED WITHOUT PRIOR WRITTEN PERMISSION FROM ALLIED MOULDED PRODUCTS.