

(4X) SNAP-IN POLYCARBONATE HINGE KNUCKLE

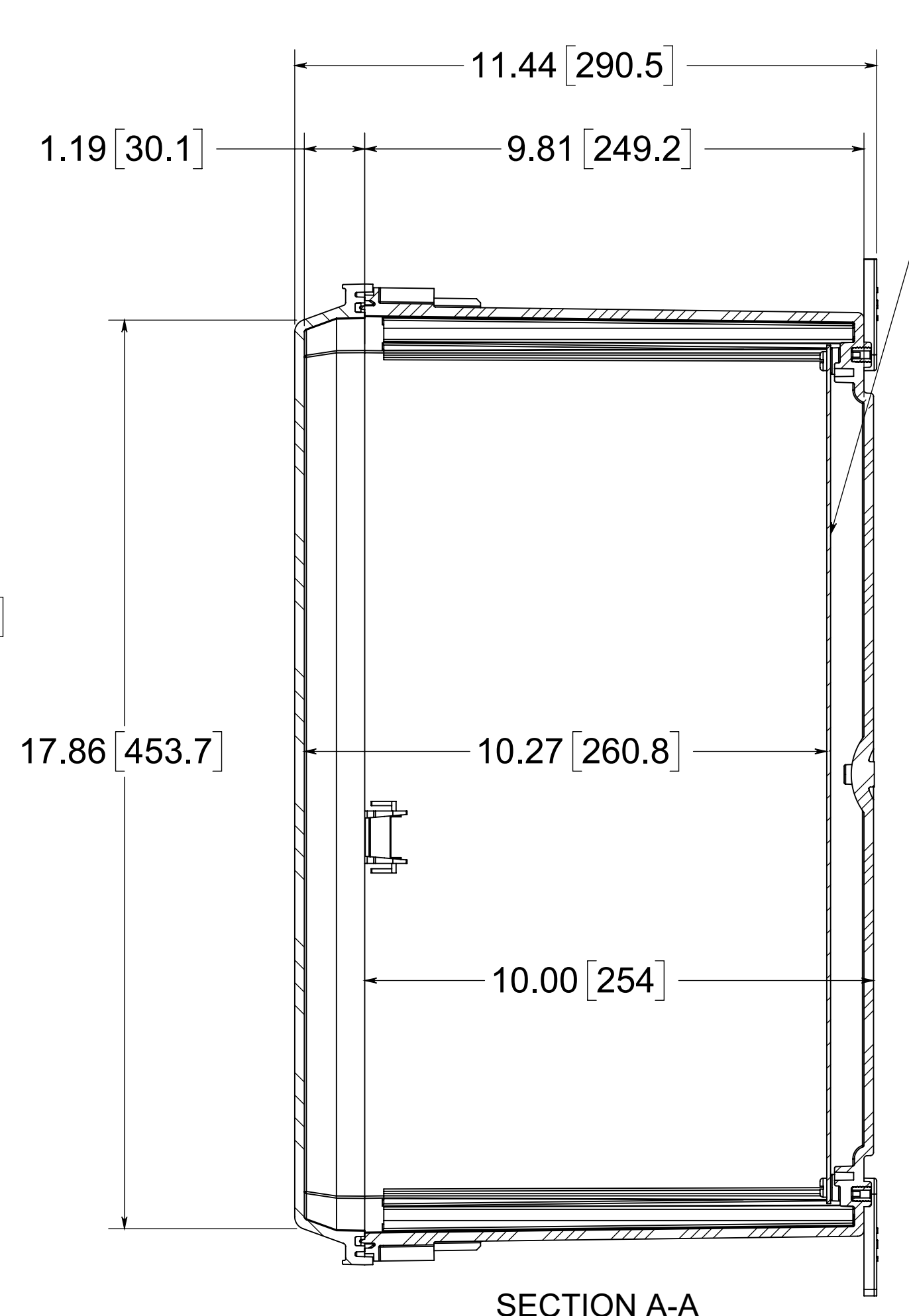

SECTION A-A

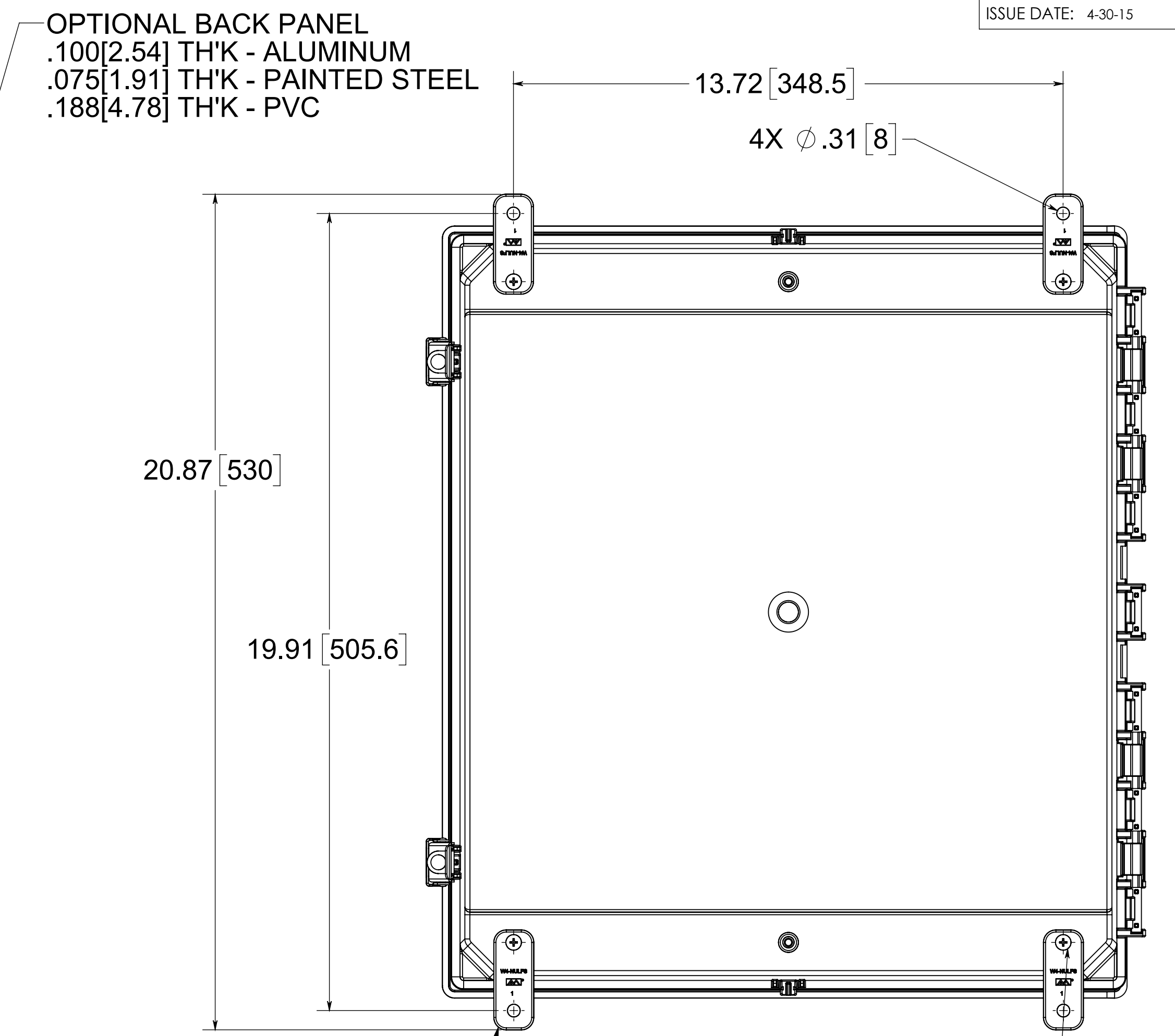

OPTIONAL BACK PANEL
 .100[2.54] TH'K - ALUMINUM
 .075[1.91] TH'K - PAINTED STEEL
 .188[4.78] TH'K - PVC

(4X) #10-32 BRASS INSERTS, AND 316 STAINLESS STEEL FLANGE AND FEET SCREWS

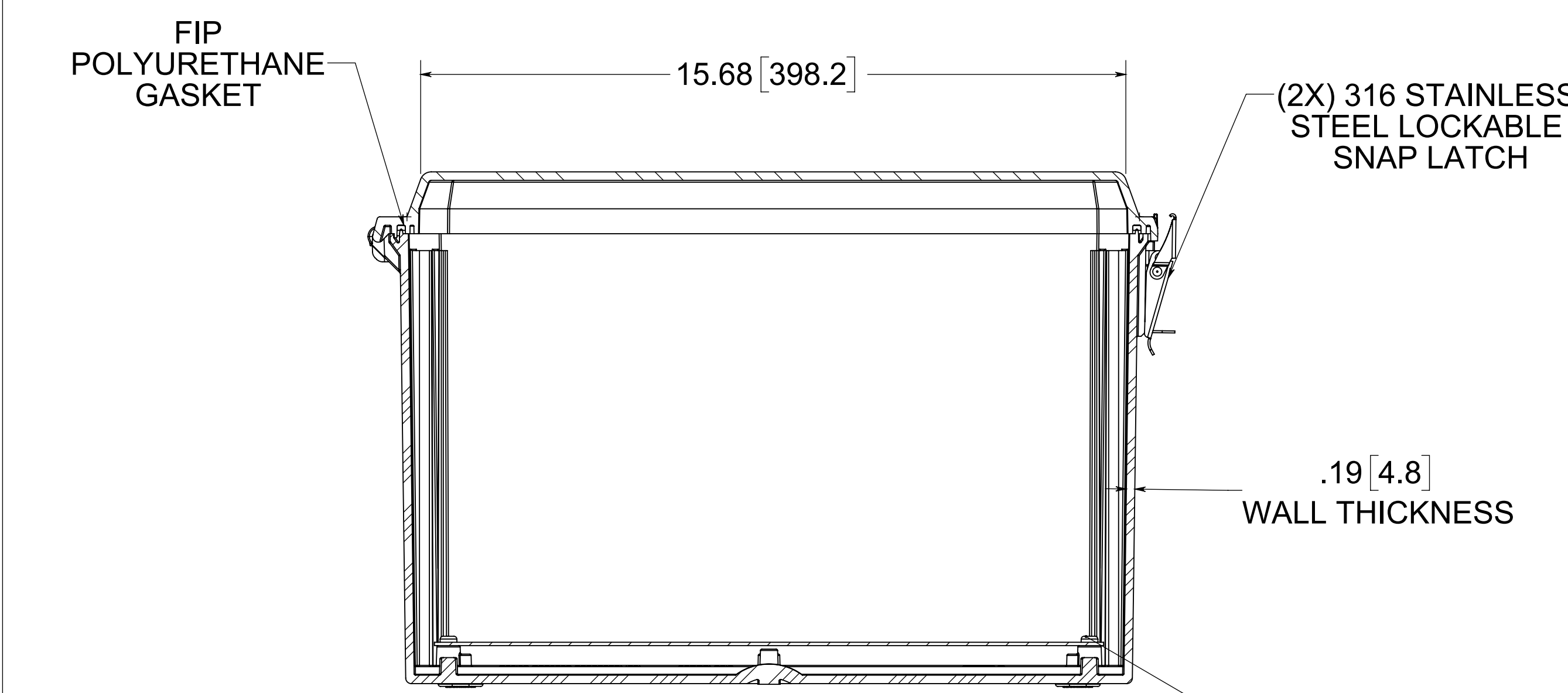

SECTION B-B

(4X) #10-32 BRASS INSERTS AND PLATED CARBON STEEL TRUSS SCREWS

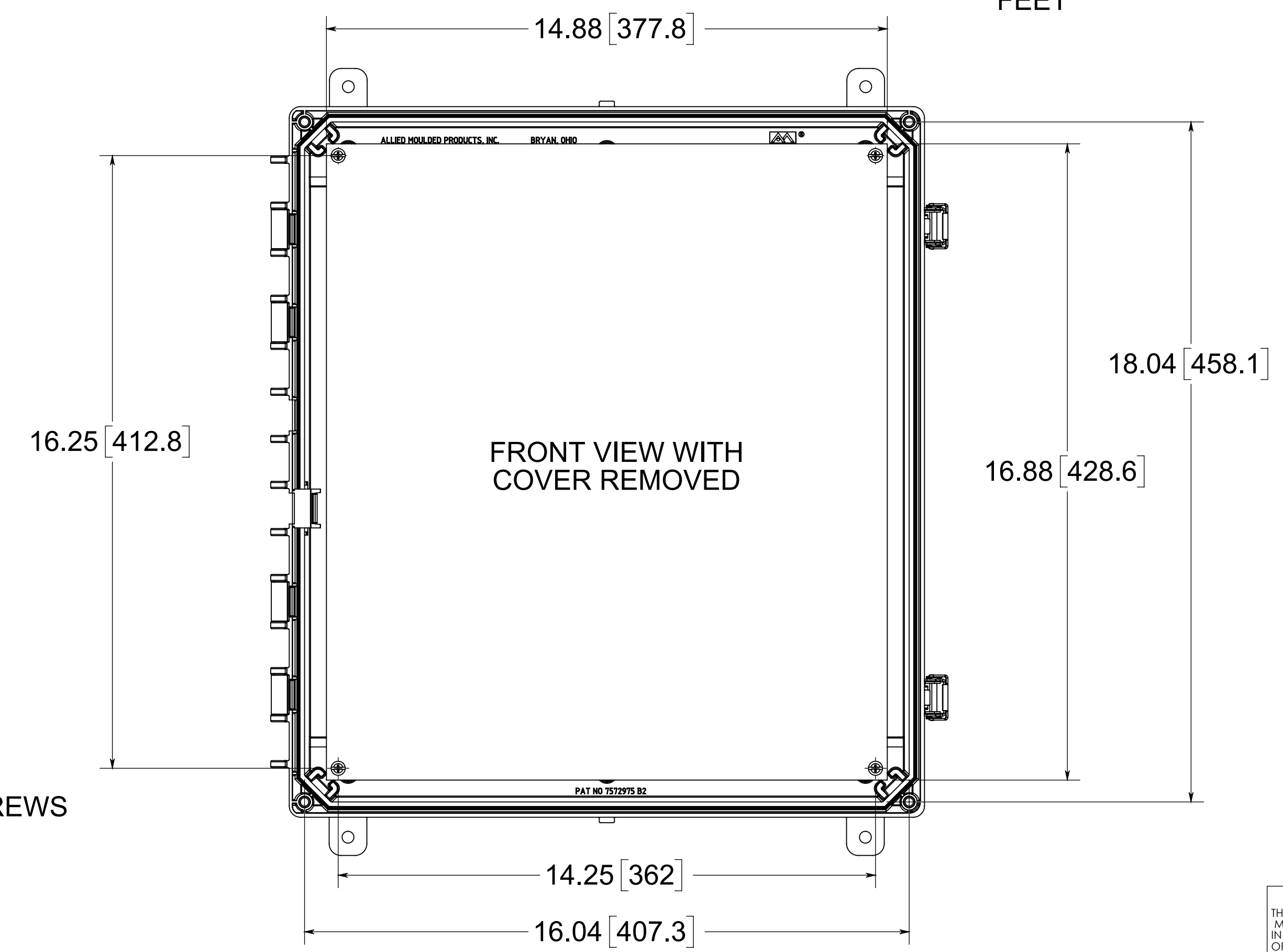

FRONT VIEW WITH COVER REMOVED

MATERIAL:
 BOX - INJECTED POLYCARBONATE
 STANDARD COVER - INJECTED POLYCARBONATE
 CLEAR COVER - INJECTED POLYCARBONATE

NOTE:
 1. DATA SUBJECT TO CHANGE

CONFIDENTIAL
 THIS MATERIAL IS OWNED BY THE ALLIED MOULDED PRODUCTS COMPANY, IS DISCLOSED IN CONFIDENCE, AND IS NOT TO BE REPRODUCED OR DISTRIBUTED WITHOUT PRIOR WRITTEN PERMISSION FROM ALLIED MOULDED PRODUCTS.

ALLIED MOULDED PRODUCTS
 BRYAN, OHIO
 The Original Fiber Glass Outlet Box
 Description
AMP Polyline
 Part No.
AMP1860L