

OPTIONAL BACK PANEL
 .100[2.54] TH'K - ALUMINUM
 .075[1.91] TH'K - PAINTED STEEL
 .188[4.78] TH'K - PVC

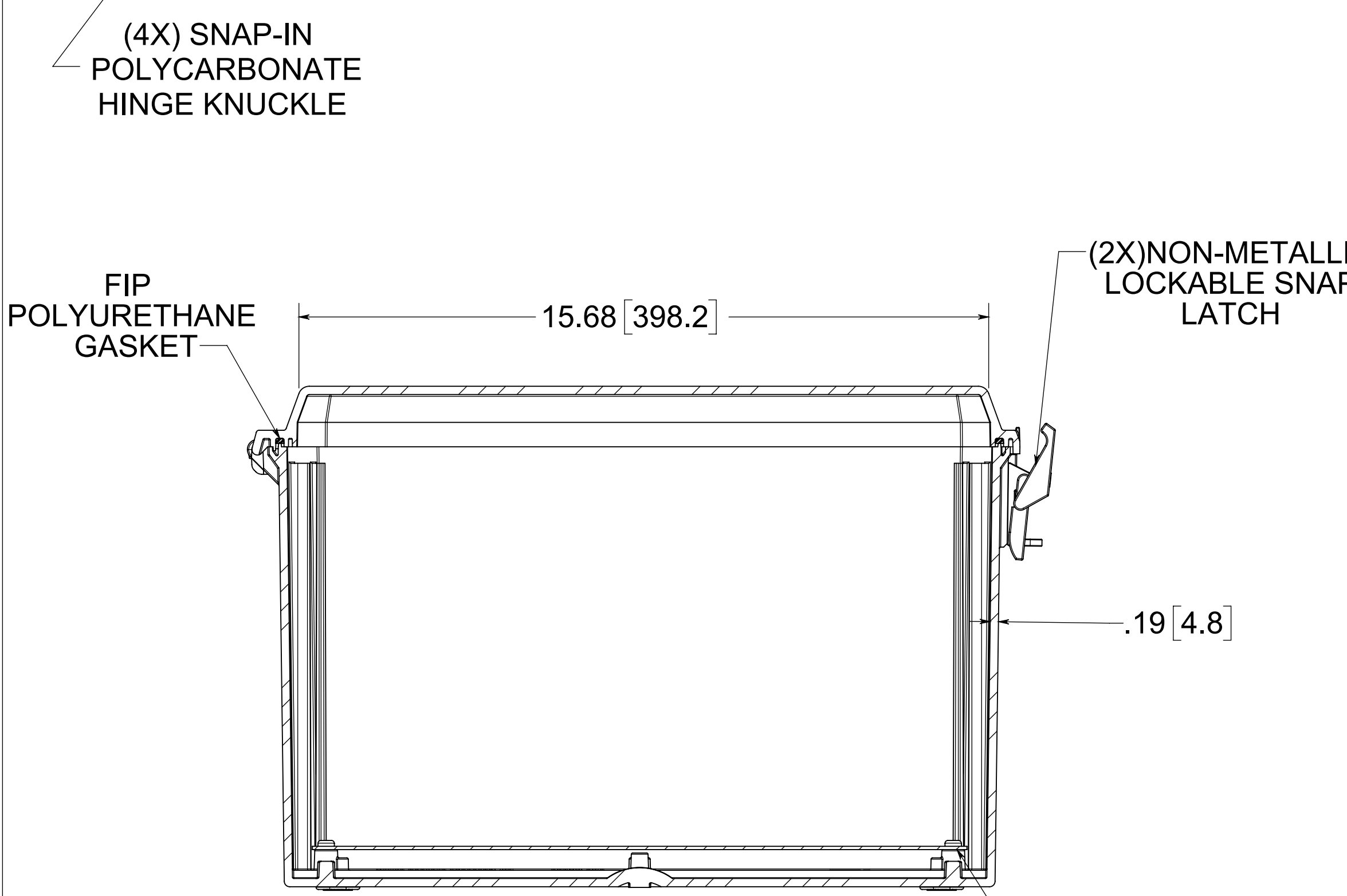

MATERIAL:
 BOX: INJECTION POLYCARBONATE
 STANDARD COVER: INJECTION POLYCARBONATE
 CLEAR COVER: INJECTION POLYCARBONATE

(4X) EACH #10-32 BRASS INSERTS AND PLATED CARBON TRUSS SCREWS

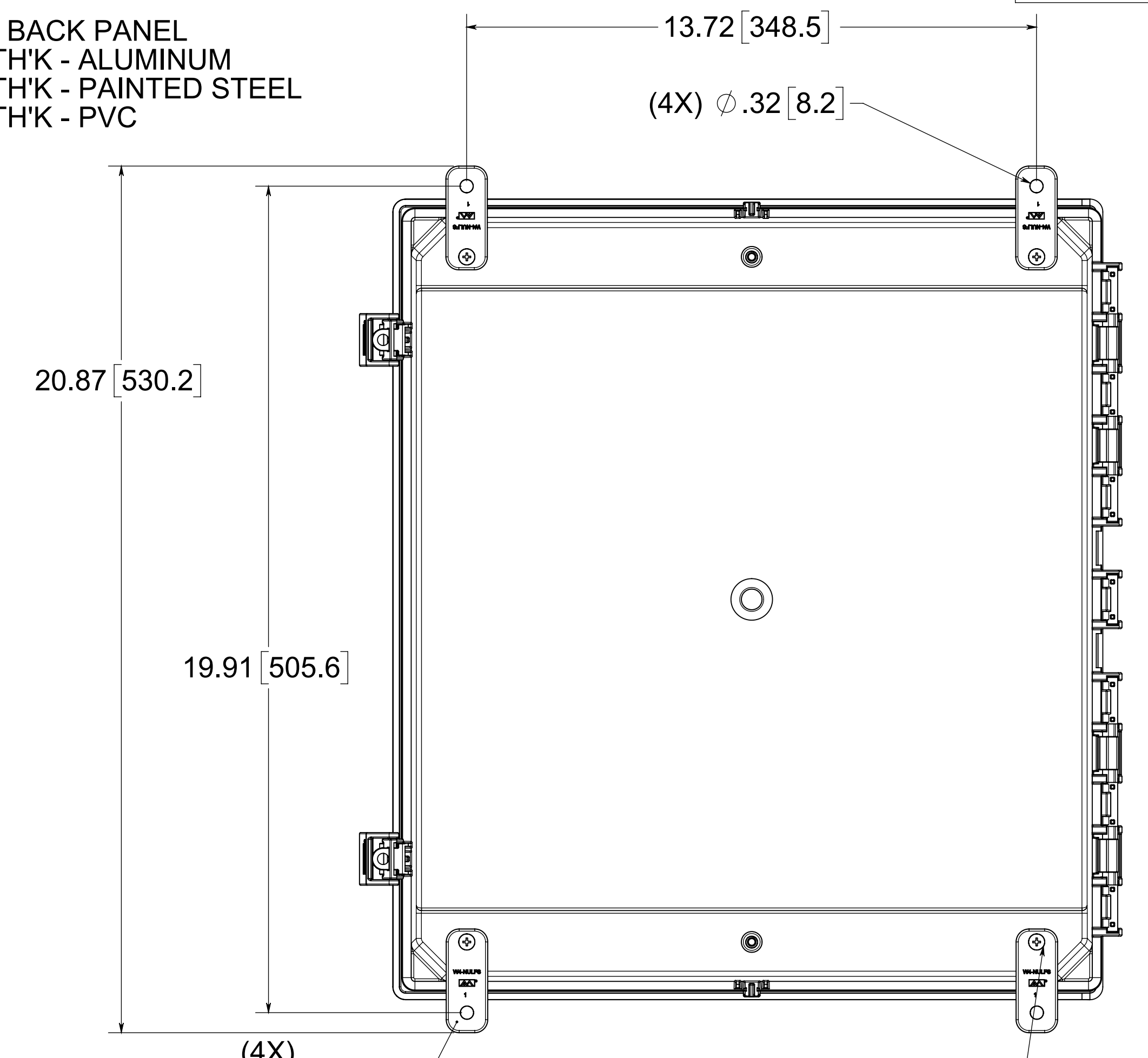
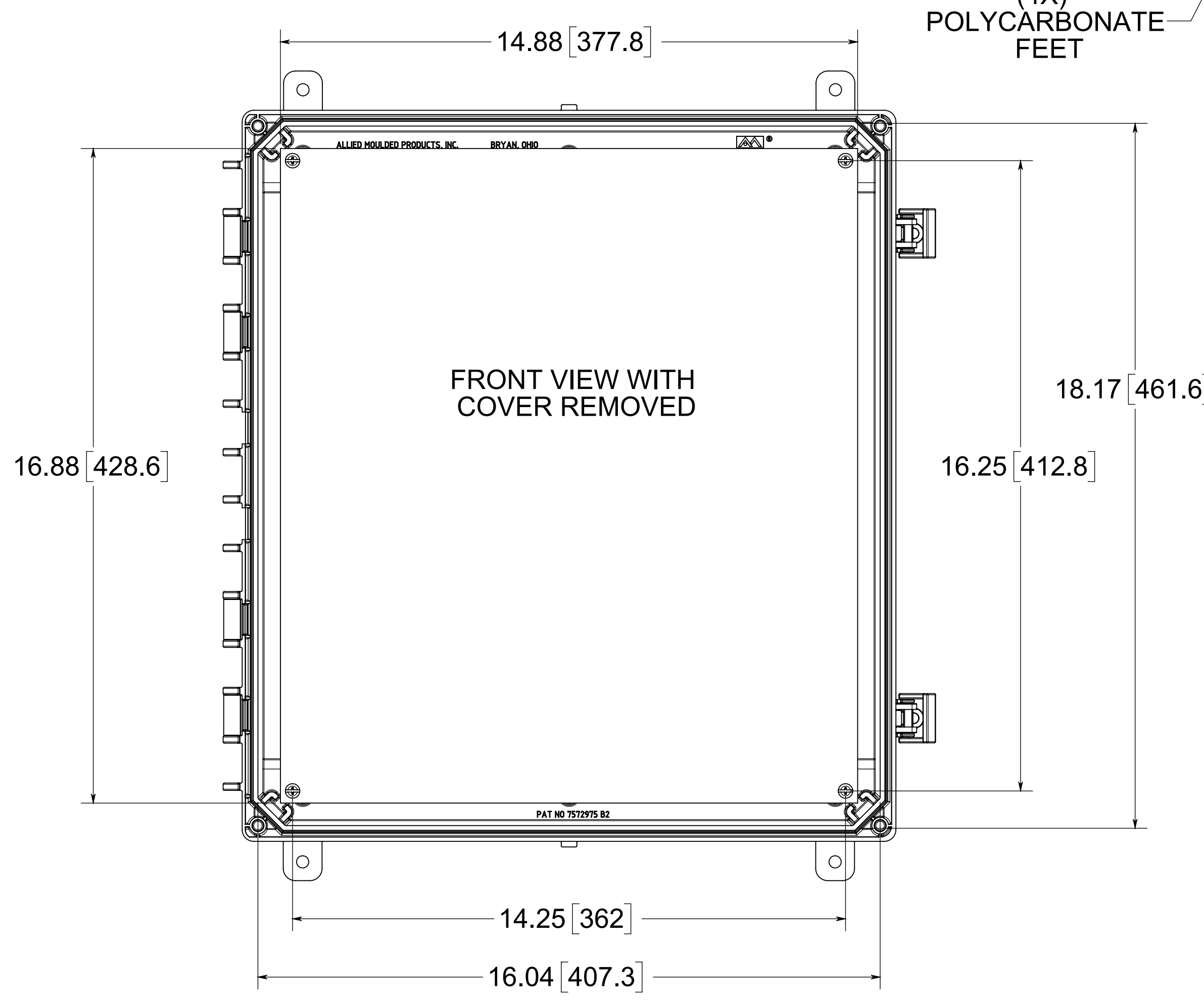

(4X) EACH #10-32 BRASS INSERTS AND 316 STAINLESS STEEL FLANGE AND FEET SCREWS

NOTE:
 1. DATA SUBJECT TO CHANGE



Description
AMP Polyline
 Part No.
AMP1860NL

CONFIDENTIAL
 THIS MATERIAL IS OWNED BY THE ALLIED MOULDED PRODUCTS COMPANY, IS DISCLOSED IN CONFIDENCE, AND IS NOT TO BE REPRODUCED OR DISTRIBUTED WITHOUT PRIOR WRITTEN PERMISSION FROM ALLIED MOULDED PRODUCTS.