

(4X) SNAP-IN POLYCARBONATE HINGE KNUCKLE

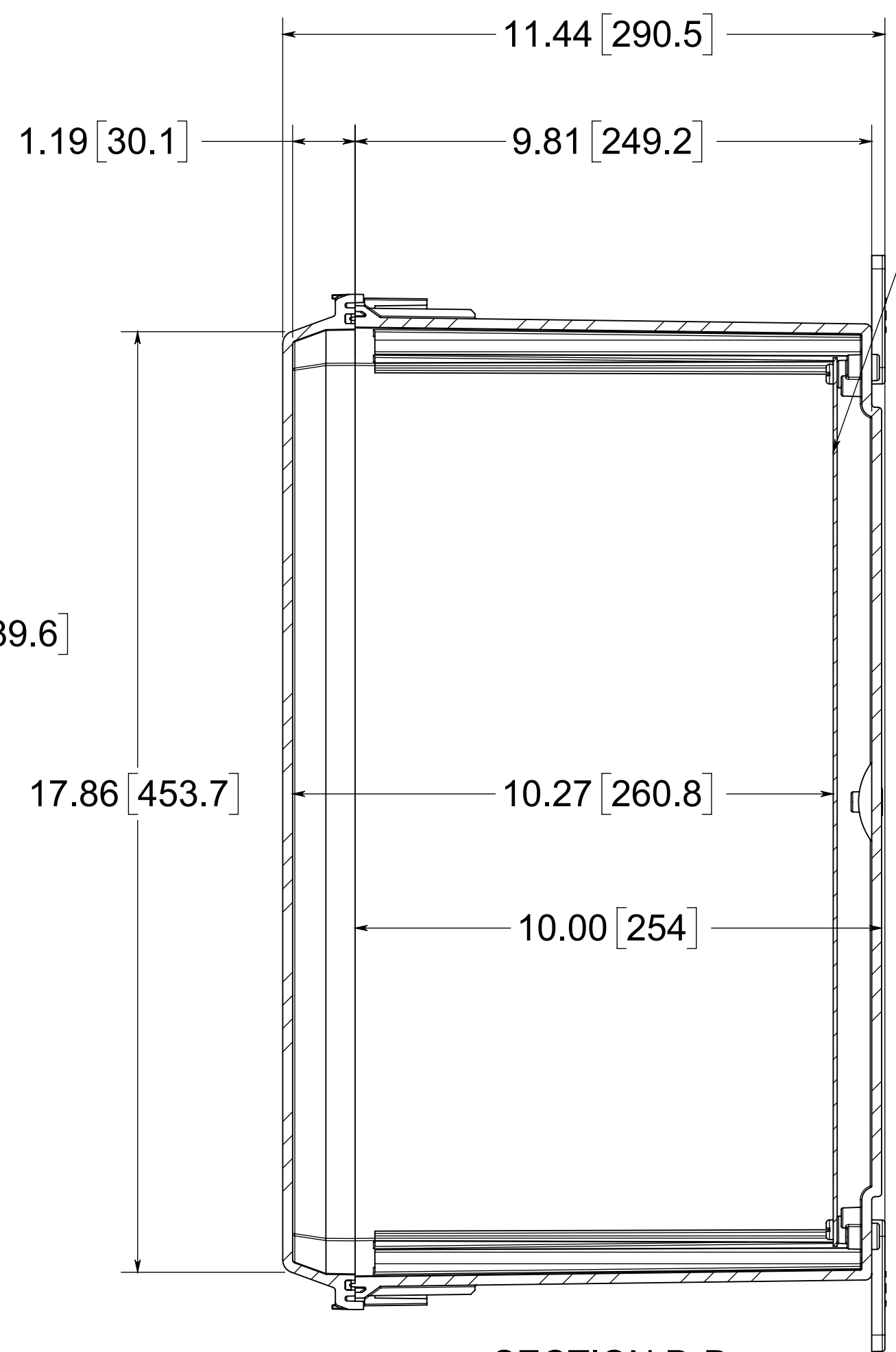

SECTION D-D

OPTIONAL BACK PANEL
 .100[2.54] TH'K - ALUMINUM
 .075[1.91] TH'K - PAINTED STEEL
 .188[4.78] TH'K - PVC

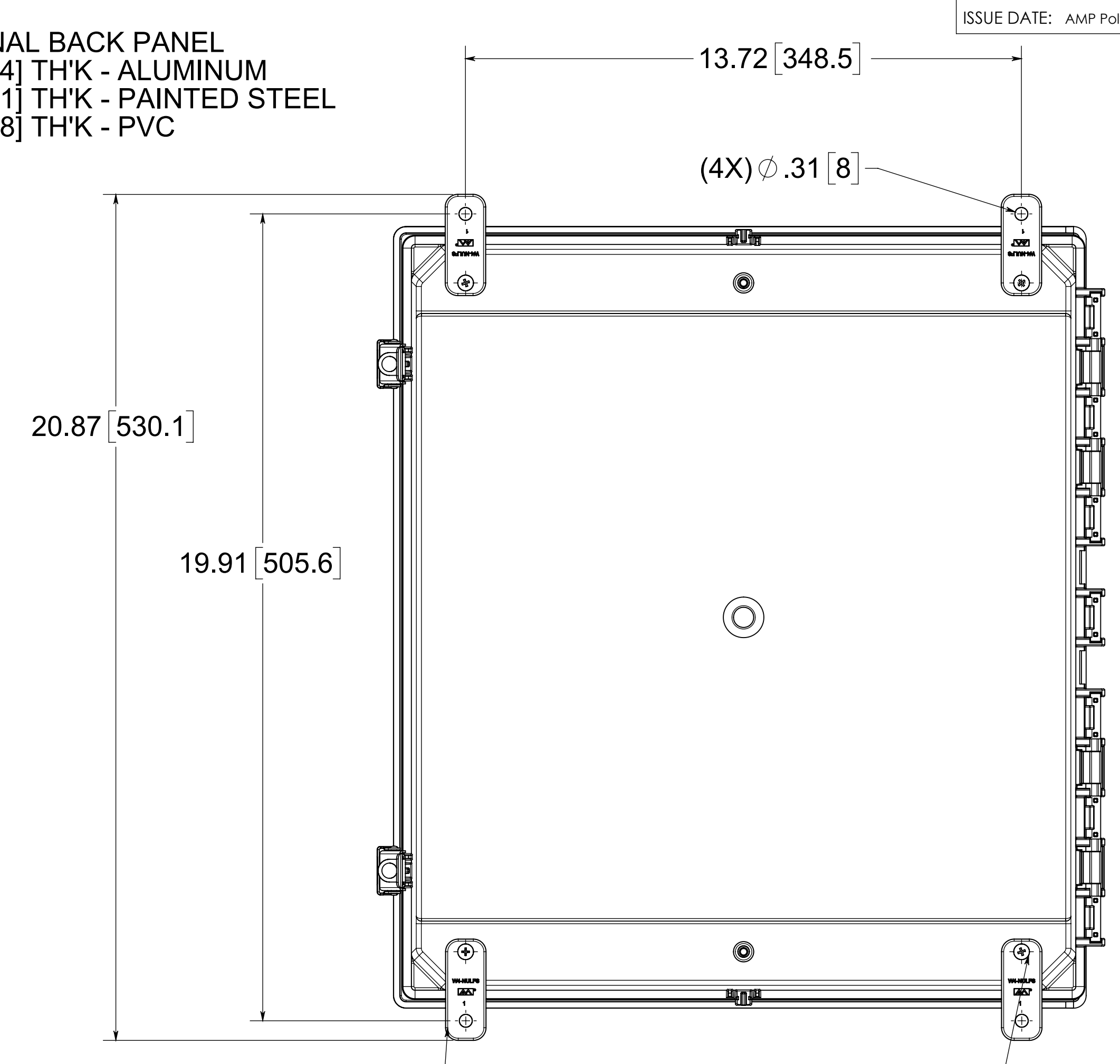

(4X) POLYCARBONATE FEET

(4X) #10-32 BRASS INSERTS, AND 316 STAINLESS STEEL FLANGE AND FEET SCREWS

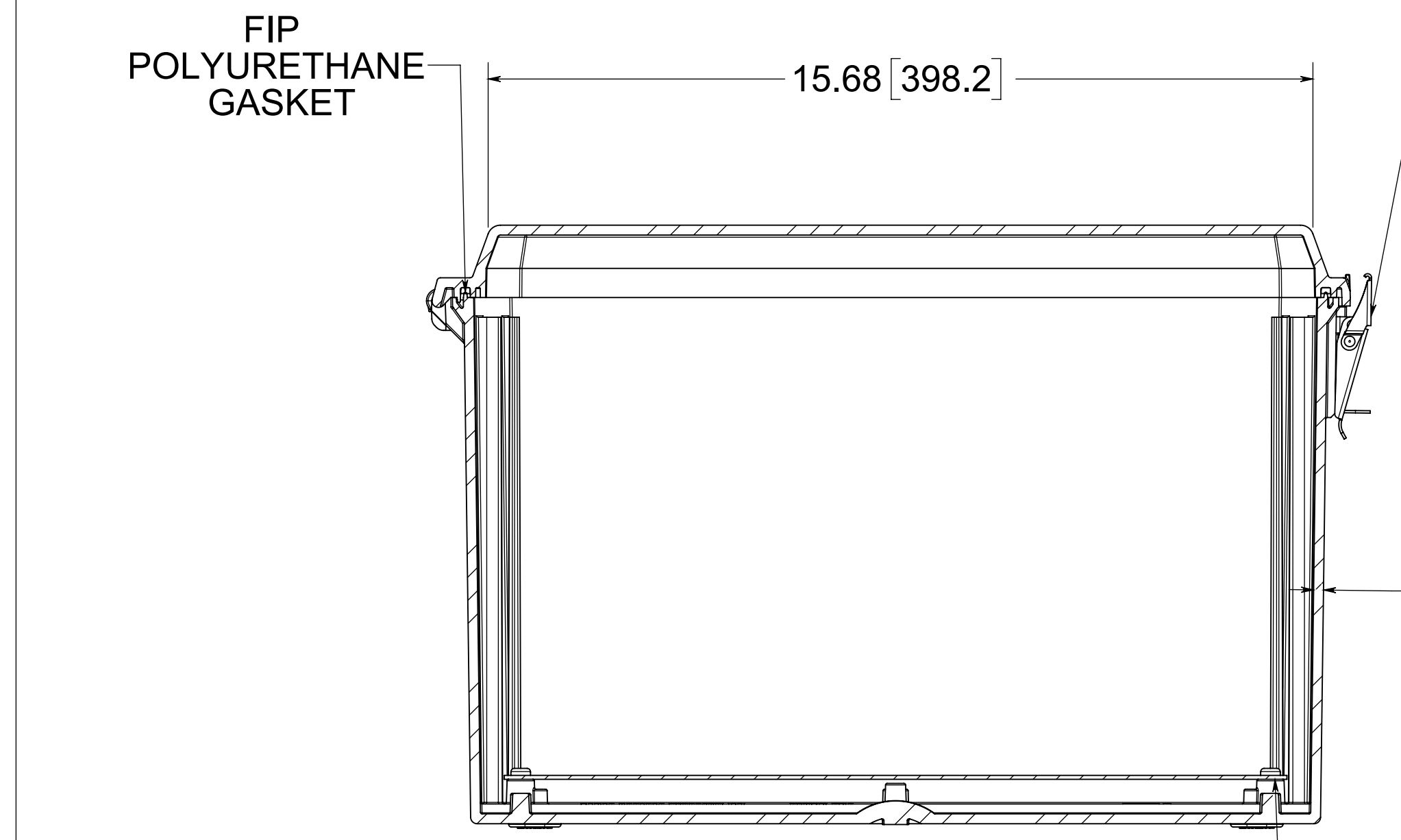

SECTION C-C

(2X) 316 STAINLESS STEEL LOCKABLE SNAP LATCH

.19 [4.8] WALL THICKNESS

(4X) #10-32 BRASS INSERTS PLATED CARBON STEEL SCREWS TO RETAIN BACK PANEL

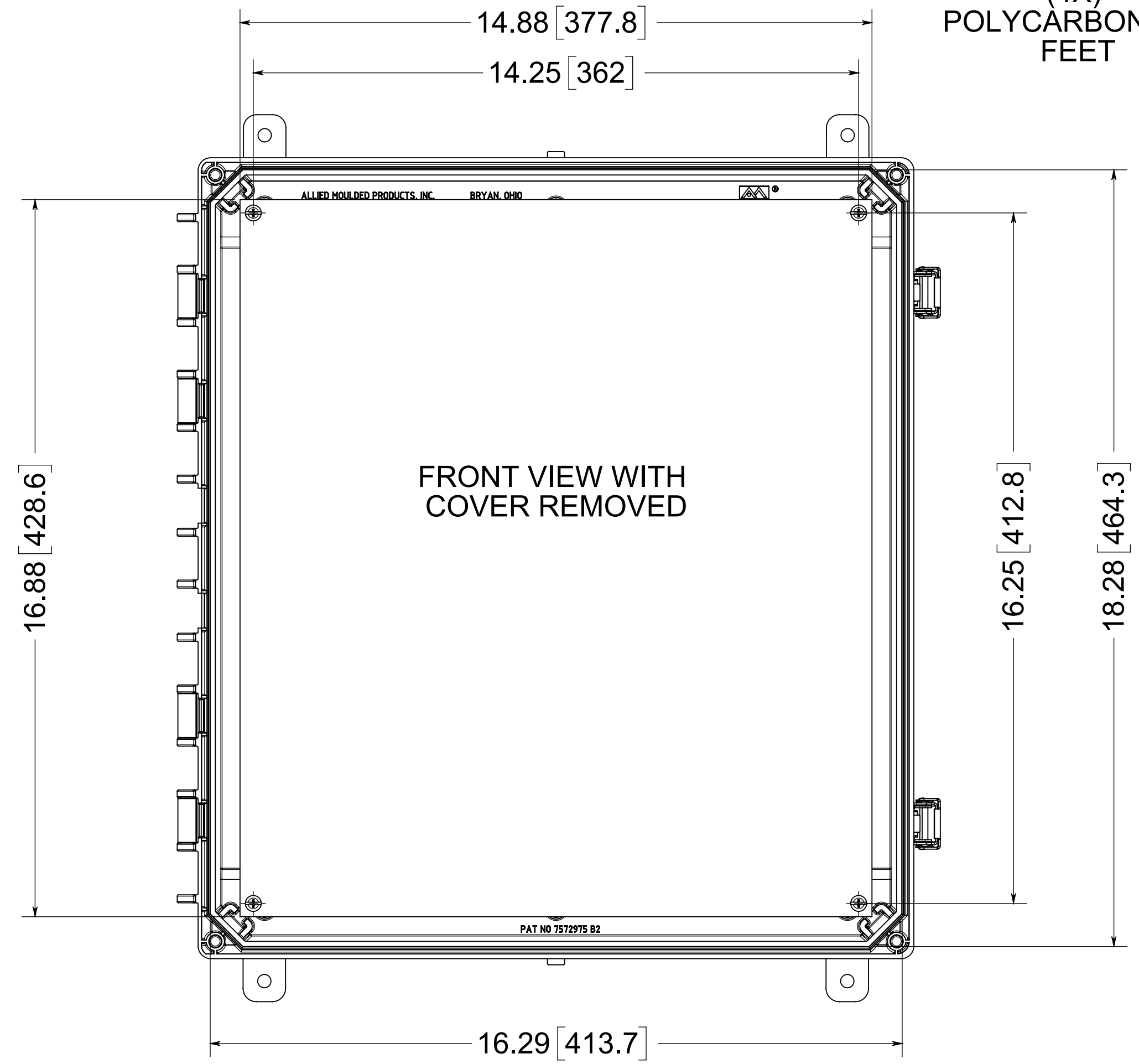

FRONT VIEW WITH COVER REMOVED

MATERIAL:
 BOX - INJECTION POLYCARBONATE
 STANDARD COVER- INJECTION POLYCARBONATE
 CLEAR COVER- INJECTION POLYCARBONATE

NOTE:
 1. DATA SUBJECT TO CHANGE

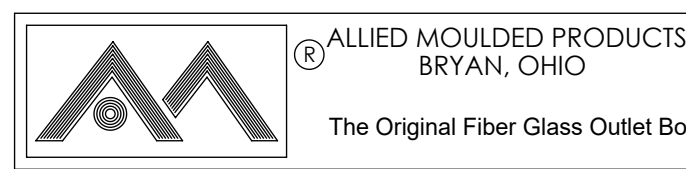

CONFIDENTIAL
 THIS MATERIAL IS OWNED BY THE ALLIED MOULDED PRODUCTS COMPANY, IS DISCLOSED IN CONFIDENCE, AND IS NOT TO BE REPRODUCED OR DISTRIBUTED WITHOUT PRIOR WRITTEN PERMISSION FROM ALLIED MOULDED PRODUCTS.

Description
AMP Polyline
 Part No.
AMP1860CCL